

PUMPAR FÖRESTÄLLNINGAR

TEKNISK DATA

PUMP MODELL	motoreffekt					begränsa HHS - HHP		hydraulisk prestanda													
	elektrisk	diesel			jockey	HHS - HHP		Q: l/min	250	275	300	350	400	450	500	600	700	750	900	990	
	kW	typ	kW NA	kW NB	kW	m ³ /h	l/min.	Q: m ³ /h	15	16,5	18	21	24	27	30	36	42	45	54	59,4	
6G/4A	7,5	L	6,2	6,7	0,75	32	534	H:mca	50	50	50	49	48	46	44	38	29,5	24			
6G/6A	11	L	10,4	11,5	1,1	32	534		76	75	75	74	72	69	66	57	44,5	36			
6G/8A	11	L	13,6	15	1,5	32	534		101	100	100	98	96	92	88	76	59	48			
6G/10A	15	L	17	18,9	2,2	32	534		126	125	125	122	119	116	111	96	74	60			
6G/12A	18,5	L	17	18,9	2,2	32	534		151	150	149	148	143	138	133	115	89	72			
6C/4A	11	L	10,4	11,5	0,75	42	700						55	55	54	53	50	47	45	42,5	37,5
6C/6A	15	L	13,6	15	1,5	42	700						83	82	81	80	76	70	68	64	56
6C/8A	18,5	L	17	18,9	1,5	42	700						111	109	108	106	101	94	89	85	75
6C/10A	30	L	24	26	2,2	42	700						138	137	135	133	126	117	114	107	93

PUMP MODELL	motoreffekt					begränsa HHS - HHP		hydraulisk prestanda												
	elektrisk	diesel			jockey	HHS - HHP		Q: l/min	500	600	700	800	900	1000	1200	1400	1600	1800		
	kW	typ	kW NA	kW NB	kW	m ³ /h	l/min.	Q: m ³ /h	30	36	42	48	54	60	72	84	96	108		
7L/3A	11	L	10,4	11,5	0,75	54	900	H:mca	54,5	53,5	51,5	49,5	46,5	43	34,5	24,5				
7L/4A	15	L	13,6	15	1,1	54	900		73	71	69	66	62	57	46,5	32,5				
7L/5A	18,5	L	17	18,9	1,5	54	900		91	89	86	82	78	72	58	41				
7L/6A	22	L	24	26	1,5	54	900		109	107	103	99	93	86	69	49				
7L/7A	30	L	24	26	2,2	54	900		128	124	120	115	109	101	81	57				
7L/8A	30	V	33	37	2,2	54	900		146	142	137	132	124	115	93	65				
7L/9A	30	V	33	37	2,2	54	900		164	160	154	148	140	129	104	73				
7C/2A	11	L	10,4	11,5	0,75	75	1250						39	38,5	37,5	36,5	34,5	31	26,5	21
7C/3A	18,5	L	17	18,9	0,75	75	1250						58	57	56	55	52	47	40	31,5
7C/4A	22	L	24	26	1,1	75	1250					78	77	75	73	69	62	53	42	
7C/5A	30	V	33	37	1,5	75	1250					97	96	94	92	86	78	67	53	
7C/6A	37	V	33	37	1,5	75	1250					117	115	113	110	103	94	80	63	
7C/7A	37	V	48	53	2,2	75	1250					136	134	132	128	120	109	93	74	

PUMP MODELL	motoreffekt					begränsa HHS - HHP		hydraulisk prestanda														
	elektrisk	diesel			jockey	HHS - HHP		Q: l/min	500	600	700	800	900	1000	1100	1200	1300	1400	1500	1600	1700	
	kW	typ	kW NA	kW NB	kW	m ³ /h	l/min.	Q: m ³ /h	30	36	42	48	54	60	66	72	78	84	90	96	102	
8B/2A	11	L	10,4	11,5	0,75	60	1000	H:mca	50	49	47,5	46	44	42	39,5	37	34	30	25,5			
8B/3A	18,5	L	17	18,9	1,1	60	1000		75	73	71	69	66	63	59	56	50	45	38			
8B/4A	22	L	24	26	1,5	60	1000		100	98	95	92	88	84	79	75	68	60	51			
8B/5A	30	V	33	37	2,2	60	1000		125	122	119	115	110	105	99	93	85	76	64			
8B/6A	37	V	33	37	2,2	60	1000		151	147	142	138	132	126	119	110	102	90	76			
8F/2A	15	L	13,6	15	0,75	72	1200						48	47	45,5	43,5	41,5	39	36,5	34	30	26,5
8F/3A	18,5	L	17	18,9	1,1	72	1200						72	70	68	65	62	58	54	50	45	40
8F/4A	30	L	24	26	1,5	72	1200						96	94	91	87	83	78	73	67	60	53
8F/5A	30	V	33	37	1,5	72	1200						120	117	113	108	104	97	91	83	75	67
8F/6A	37	V	48	53	2,2	72	1200						144	141	136	130	124	117	109	100	90	80

PUMPAR FÖRESTÄLLNINGAR

TEKNISK DATA

PUMP MODELL	motoreffekt					begränsa HHS - HHP		hydraulisk prestanda											
	elektrisk	diesel			jockey			Q: l/min	800	1000	1200	1400	1600	1800	2000	2200	2400	2600	
	kW	typ	kW NA	kW NB	kW	m ³ /h	l/min.	Q: m ³ /h	48	60	72	84	96	108	120	132	144	156	
8L/2A	15	L	13,6	15	0,75	90	1500	H:mca	46	44,5	42,5	40	36,5	32,5	27,5	21,5			
8L/3A	22	L	24	26	1,1	90	1500		69	67	64	60	55	48,5	41,5	32,5			
8L/4A	30	V	33	37	1,5	90	1500		92	89	85	80	73	65	55	43			
8L/5A	37	V	33	37	1,5	90	1500		115	112	106	100	91	81	69	54			
8L/6A	45	V	48	53	2,2	90	1500		138	134	128	119	109	97	83	65			
8C/2A	18,5	L	17	18,9	0,75	111	1850				48,5	47	45	42,5	40	36,5	32,5	28,5	
8C/3A	30	V	33	37	1,1	111	1850				73	71	68	64	59,5	55	49	42,5	
8C/4A	37	V	48	53	1,5	111	1850				97	94	90	85	80	73	65	57	
8C/5A	45	V	48	53	2,2	111	1850				121	118	113	107	100	91	82	71	
8C/6A	55	V	65	73	2,2	111	1850				145	141	135	128	119	109	98	85	

PUMP MODELL	motoreffekt					begränsa HHS - HHP		hydraulisk prestanda										
	elektrisk	diesel			jockey			Q: l/min	2500	3000	3500	4000	4500	5000	5500	6000	6500	7000
	kW	typ	kW NA	kW NB	kW	m ³ /h	l/min.	Q: m ³ /h	150	180	210	240	270	300	330	360	390	420
10F/1B	37	V	33	37	0,75	275	4584	H:mca	37	36	34	32,5	30,5	28,5	25,5	23	20	15,5
10F/1A	45	V	48	53	0,75	275	4584		41	39,5	38	36,5	34,5	32,5	30	27	24,5	20,5
10F/2E	45	V	48	53	0,75	240	4000		55	52	48	44	39,5	34	26,5	18,5		
10F/2CD	55	V	65	73	1,1	252	4200		64	61	57	54	49,5	45	39	32,5	24,5	
10F/2BC	75	V	65	73	1,1	252	4200		71	68	65	61	57	53	47	41,5	34,5	
10F/3CD	90	V	100	110	1,5	252	4200		95	91	86	80	74	67	58	49	37	
10F/3B	110	V	100	110	1,5	275	4584		111	108	103	97	92	85	77	69	59	47

PUMP MODELL	motoreffekt					begränsa HHS - HHP		hydraulisk prestanda								
	elektrisk	diesel			jockey			Q: l/min	2400	3000	3500	4000	4500	5000	5500	5700
	kW	typ	kW NA	kW NB	kW	m ³ /h	l/min.	Q: m ³ /h	144	180	213	240	270	300	330	342
12B/1B	37	V	48	53	0,75	213	3550	H:mca	53	50	46	42	37	31	23,5	
12B/1A	45	V	48	53	0,75	213	3550		58	55	51	47	42	36,5	29	26,5
12B/2C	75	V	65	73	1,5	213	3550		94	89	81	72	62	49,5		
12B/2B	75	V	100	110	1,5	213	3550		106	100	92	84	74	63	47	
12B/3C	110	V	100	110	2,2	213	3550		141	133	121	108	93	74		

VTS P1M

TEKNISK DATA

MODELLGRUPP	MOTOR PUMP			ratvinklig drivenhet		JOCKEY PUMP		LINESKAFT	FLÖDESMÄTARE KIT
	diesel motor								
VTS P1M	mod.	kW NA	kW NA	mod.	DN	mod.	kW	mod.	mod.
EN VTS P1M 6G/4A LC+S4/11	15LD440	6,2	6,7	R16/3L/20	80	S4/11	0,75	LA3/20	CM50 - V50
EN VTS P1M 6G/6A LC+S4/16	25LD425	10,4	11,5	R16/3L/20	80	S4/16	1,1	LA3/20	CM50 - V50
EN VTS P1M 6G/8A LC+S4/21	12LD477/2	13,6	15	R16/3L/20	80	S4/21	1,5	LA3/20	CM50 - V50
EN VTS P1M 6G/10A LC+S4/32	9LD625/2	17	18,9	R16/3L/20	80	S4/32	2,2	LA3/20	CM50 - V50
EN VTS P1M 6G/12A LC+S4/32	9LD625/2	17	18,9	R16/3L/20	80	S4/32	2,2	LA3/20	CM50 - V50
EN VTS P1M 6C/4A LC+S4/11	25LD425	10,4	11,5	R16/3L/20	80	S4/11	0,75	LA3/20	CM65 - V50
EN VTS P1M 6C/6A LC+S4/21	12LD477/2	13,6	15	R16/3L/20	80	S4/21	1,5	LA3/20	CM65 - V50
EN VTS P1M 6C/8A LC+S4/21	9LD625/2	17	18,9	R16/3L/20	80	S4/21	1,5	LA3/20	CM65 - V50
EN VTS P1M 6C/10A LC+S4/32	11LD626/3	24	26	R16/3L/24	80	S4/32	2,2	LA3/24	CM65 - V50
EN VTS P1M 7L/3A LC+S4/11	25LD425	10,4	11,5	R16/3L/20	80	S4/11	0,75	LA3/20	CM65 - V65
EN VTS P1M 7L/4A LC+S4/16	12LD477/2	13,6	15	R16/3L/20	80	S4/16	1,1	LA3/20	CM65 - V65
EN VTS P1M 7L/5A LC+S4/21	9LD625/2	17	18,9	R16/3L/20	80	S4/21	1,5	LA3/20	CM65 - V65
EN VTS P1M 7L/6A LC+S4/21	11LD626/3	24	26	R16/3L/20	80	S4/21	1,5	LA3/20	CM65 - V65
EN VTS P1M 7L/7A LC+S4/32	11LD626/3	24	26	R16/3L/24	80	S4/32	2,2	LA3/24	CM65 - V65
EN VTS P1M 7L/8A VC+S4/32	D703LE0	33	37	R16/3L/24	80	S4/32	2,2	LA3/24	CM65 - V65
EN VTS P1M 7L/9A VC+S4/32	D703LE0	33	37	R16/3L/24	80	S4/32	2,2	LA3/24	CM65 - V65
EN VTS P1M 7C/2A LC+S4/11	25LD425	10,4	11,5	R16/4L/20	100	S4/11	0,75	LA4/20	CM80 - V65
EN VTS P1M 7C/3A LC+S4/11	9LD625/2	17	18,9	R16/4L/20	100	S4/11	0,75	LA4/20	CM80 - V65
EN VTS P1M 7C/4A LC+S4/16	11LD626/3	24	26	R16/4L/20	100	S4/16	1,1	LA4/20	CM80 - V65
EN VTS P1M 7C/5A VC+S4/21	D703LE0	33	37	R26/4L/24	100	S4/21	1,5	LA4/24	CM80 - V65
EN VTS P1M 7C/6A VC+S4/21	D703LE0	33	37	R26/4L/24	100	S4/21	1,5	LA4/24	CM80 - V65
EN VTS P1M 7C/7A VC+S4/32	D703LTE0	48	53	R26/4L/24	100	S4/32	2,2	LA4/24	CM80 - V65
EN VTS P1M 8B/2A LC+S4/11	25LD425	10,4	11,5	R16/3L/20	80	S4/11	0,75	LA3/20	CM65 - V65
EN VTS P1M 8B/3A LC+S4/16	9LD625/2	17	18,9	R16/3L/20	80	S4/16	1,1	LA3/20	CM65 - V65
EN VTS P1M 8B/4A LC+S4/21	11LD626/3	24	26	R16/3L/20	80	S4/21	1,5	LA3/20	CM65 - V65
EN VTS P1M 8B/5A VC+S4/32	D703LE0	33	37	R26/3L/24	80	S4/32	2,2	LA3/24	CM65 - V65
EN VTS P1M 8B/6A VC+S4/32	D703LE0	33	37	R26/3L/24	80	S4/32	2,2	LA3/24	CM65 - V65
EN VTS P1M 8F/2A LC+S4/11	12LD477/2	13,6	15	R16/4L/20	100	S4/11	0,75	LA4/20	CM80 - V65
EN VTS P1M 8F/3A LC+S4/16	9LD625/2	17	18,9	R16/4L/20	100	S4/16	1,1	LA4/20	CM80 - V65
EN VTS P1M 8F/4A LC+S4/21	11LD626/3	24	26	R26/4L/24	100	S4/21	1,5	LA4/24	CM80 - V65
EN VTS P1M 8F/5A VC+S4/21	D703LE0	33	37	R26/4L/24	100	S4/21	1,5	LA4/24	CM80 - V65
EN VTS P1M 8F/6A VC+S4/32	D703LTE0	48	53	R26/4L/24	100	S4/32	2,2	LA4/24	CM80 - V65
EN VTS P1M 8L/2A LC+S4/11	12LD477/2	13,6	15	R16/5/20	125	S4/11	0,75	LA5/20	CM80 - V80
EN VTS P1M 8L/3A LC+S4/16	11LD626/3	24	26	R16/5/20	125	S4/16	1,1	LA5/20	CM80 - V80
EN VTS P1M 8L/4A VC+S4/21	D703LE0	33	37	R26/5/24	125	S4/21	1,5	LA5/24	CM80 - V80
EN VTS P1M 8L/5A VC+S4/21	D703LE0	33	37	R26/5/24	125	S4/21	1,5	LA5/24	CM80 - V80
EN VTS P1M 8L/6A VC+S4/32	D703LTE0	48	53	R26/5/24	125	S4/32	2,2	LA5/24	CM80 - V80
EN VTS P1M 8C/2A LC+S4/11	9LD625/2	17	18,9	R16/5/20	125	S4/11	0,75	LA5/20	CM100 - V80
EN VTS P1M 8C/3A VC+S4/16	D703LE0	33	37	R26/5/24	125	S4/16	1,1	LA5/24	CM100 - V80
EN VTS P1M 8C/4A VC+S4/21	D703LTE0	48	53	R26/5/24	125	S4/21	1,5	LA5/24	CM100 - V80
EN VTS P1M 8C/5A VC+S4/32	D703LTE0	48	53	R42/5/30	125	S4/32	2,2	LA5/30	CM100 - V80
EN VTS P1M 8C/6A VC+S4/32	D754TPE2	65	73	R42/5/30	125	S4/32	2,2	LA5/30	CM100 - V80
EN VTS P1M 10F/1B VC+S4/11	D703LE0	33	37	R26/6/24	125	S4/11	0,75	LA6/24	CM150 - V125
EN VTS P1M 10F/1A VC+S4/11	D703LTE0	48	53	R26/6/30	150	S4/11	0,75	LA6/30	CM150 - V125
EN VTS P1M 10F/2E VC+S4/11	D703LTE0	48	53	R42/6/30	150	S4/11	0,75	LA6/30	CM150 - V125
EN VTS P1M 10F/2CD VC+S4/16	D754TPE2	65	73	R42/6/30	150	S4/16	1,1	LA6/30	CM150 - V125
EN VTS P1M 10F/2BC VC+S4/16	D754TPE2	65	73	R42/6/30	150	S4/16	1,1	LA6/30	CM150 - V125
EN VTS P1M 10F/3CD VC+S4/21	D756IPE2	100	110	R75/6/30	150	S4/21	1,5	LA6/30	CM150 - V125
EN VTS P1M 10F/3B VC+S4/21	D756IPE2	100	110	R75/6/30	150	S4/21	1,5	LA6/30	CM150 - V125
EN VTS P1M 12B/1B VC+S4/11	D703LTE0	48	53	R26/7/30	175	S4/11	0,75	LA7/30	CM125 - V125
EN VTS P1M 12B/1A VC+S4/11	D703LTE0	48	53	R42/7/30	175	S4/11	0,75	LA7/30	CM125 - V125
EN VTS P1M 12B/2C VC+S4/21	D754TPE2	65	73	R75/7/30	175	S4/21	1,5	LA7/30	CM125 - V125
EN VTS P1M 12B/2B VC+S4/21	D756IPE2	100	110	R75/7/30	175	S4/21	1,5	LA7/30	CM125 - V125
EN VTS P1M 12B/3C VC+S4/32	D756IPE2	100	110	R75/7/30	175	S4/32	2,2	LA7/30	CM125 - V125

VTS P1M

DIMENSIONER

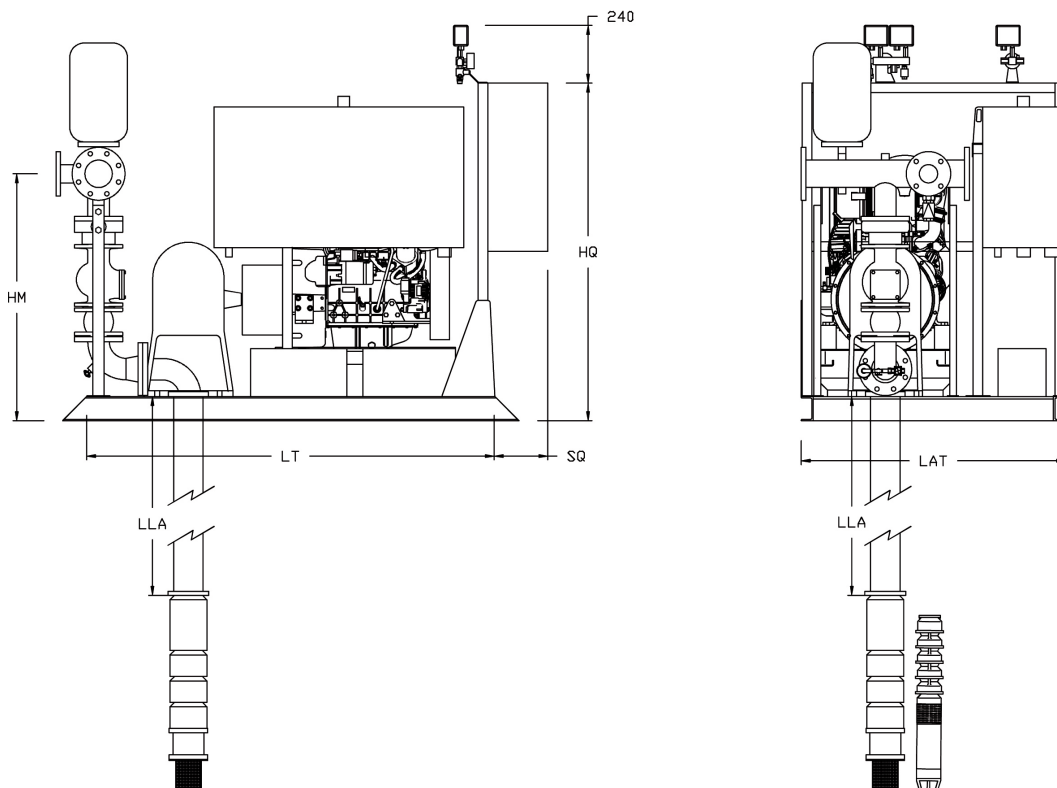

MODELLGRUPP	LEVERANS		JOCKEY PUMP	HM	LAT	LT	LC	HQ	SQ	LLA
	ventiler kit	grenrör								
VTS P1M	DN	DN	DN AxM	mm	mm	mm	mm	mm	mm	mm
EN VTS P1M 6G/4A LC+S4/11	50	80 - F50	1¼"	997	1000	1400	700	1400	230	3050
EN VTS P1M 6G/6A LC+S4/16	50	80 - F50	1¼"	997	1000	1400	700	1401	230	3050
EN VTS P1M 6G/8A LC+S4/21	50	80 - F50	1¼"	997	1000	1600	700	1402	230	3050
EN VTS P1M 6G/10A LC+S4/32	50	80 - F50	1¼"	997	1200	1600	900	1403	230	3050
EN VTS P1M 6G/12A LC+S4/32	50	80 - F50	1¼"	997	1200	1600	900	1404	230	3050
EN VTS P1M 6C/4A LC+S4/11	65	80 - F50	1¼"	1050	1000	1400	700	1405	230	3050
EN VTS P1M 6C/6A LC+S4/21	65	80 - F50	1¼"	1050	1000	1600	700	1406	230	3050
EN VTS P1M 6C/8A LC+S4/21	65	80 - F50	1¼"	1050	1200	1600	900	1407	230	3050
EN VTS P1M 6C/10A LC+S4/32	65	80 - F50	1¼"	1050	1400	1800	1100	1408	230	3050
EN VTS P1M 7L/3A LC+S4/11	80	100 - F65	1¼"	1047	1000	1400	700	1409	230	3050
EN VTS P1M 7L/4A LC+S4/16	80	100 - F65	1¼"	1047	1000	1600	700	1410	230	3050
EN VTS P1M 7L/5A LC+S4/21	80	100 - F65	1¼"	1047	1200	1600	900	1411	230	3050
EN VTS P1M 7L/6A LC+S4/21	80	100 - F65	1¼"	1047	1400	1800	1100	1412	230	3050
EN VTS P1M 7L/7A LC+S4/32	80	100 - F65	1¼"	1047	1400	1800	1100	1413	230	3050
EN VTS P1M 7L/8A VC+S4/32	80	100 - F65	1¼"	1047	1000	1800	700	1414	230	3050
EN VTS P1M 7L/9A VC+S4/32	80	100 - F65	1¼"	1047	1000	1800	700	1415	230	3050
EN VTS P1M 7C/2A LC+S4/11	80	100 - F65	1¼"	1047	1000	1400	700	1416	230	3050
EN VTS P1M 7C/3A LC+S4/11	80	100 - F65	1¼"	1047	1200	1600	900	1417	230	3050
EN VTS P1M 7C/4A LC+S4/16	80	100 - F65	1¼"	1047	1400	1800	1100	1418	230	3050
EN VTS P1M 7C/5A VC+S4/21	80	100 - F65	1¼"	1047	1000	1800	700	1419	230	3050
EN VTS P1M 7C/6A VC+S4/21	80	100 - F65	1¼"	1047	1000	1800	700	1420	230	3050
EN VTS P1M 7C/7A VC+S4/32	80	100 - F65	1¼"	1047	1000	1800	700	1421	230	3050
EN VTS P1M 8B/2A LC+S4/11	80	100 - F65	1¼"	1047	1000	1400	700	1422	230	3050
EN VTS P1M 8B/3A LC+S4/16	80	100 - F65	1¼"	1047	1200	1600	900	1423	230	3050
EN VTS P1M 8B/4A LC+S4/21	80	100 - F65	1¼"	1047	1400	1800	1100	1424	230	3050
EN VTS P1M 8B/5A VC+S4/32	80	100 - F65	1¼"	1047	1000	1800	700	1425	230	3050
EN VTS P1M 8B/6A VC+S4/32	80	100 - F65	1¼"	1047	1000	1800	700	1426	230	3050

VTS P1M

DIMENSIONER

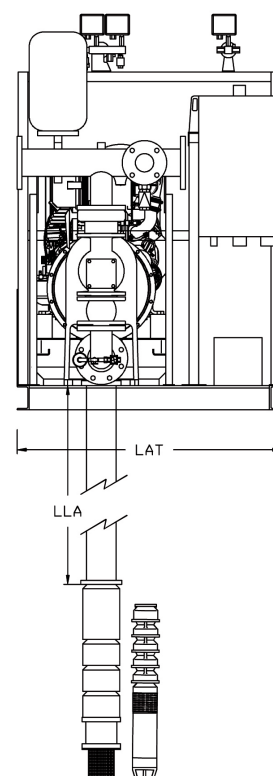
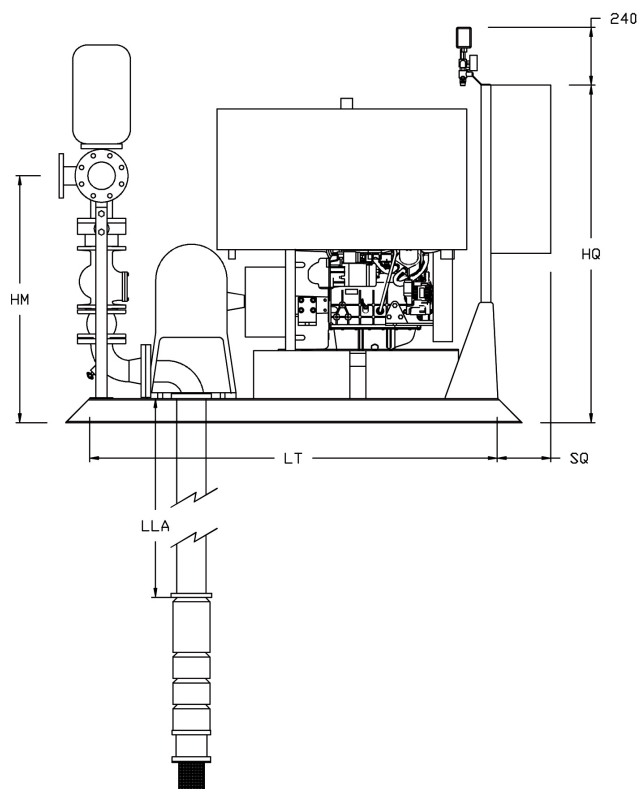

MODELLGRUPP	LEVERANS		JOCKEY PUMP	HM	LAT	LT	LC	HQ	SQ	LLA
	ventiler kit	grenrör								
VTS P1M	DN	DN	DN AxM	mm	mm	mm	mm	mm	mm	mm
EN VTS P1M 8F/2A LC+S4/11	80	100 - F65	1¼"	1047	1000	1600	700	1427	230	3050
EN VTS P1M 8F/3A LC+S4/16	80	100 - F65	1¼"	1047	1200	1600	900	1428	230	3050
EN VTS P1M 8F/4A LC+S4/21	80	100 - F65	1¼"	1047	1400	1800	1100	1429	230	3050
EN VTS P1M 8F/5A VC+S4/21	80	100 - F65	1¼"	1047	1000	1800	700	1430	230	3050
EN VTS P1M 8F/6A VC+S4/32	80	100 - F65	1¼"	1047	1000	1800	700	1431	230	3050
EN VTS P1M 8L/2A LC+S4/11	100	125 - F80	1¼"	1169	1000	1600	700	1432	230	3050
EN VTS P1M 8L/3A LC+S4/16	100	125 - F80	1¼"	1169	1400	1800	1100	1433	230	3050
EN VTS P1M 8L/4A VC+S4/21	100	125 - F80	1¼"	1169	1000	2000	700	1434	230	3050
EN VTS P1M 8L/5A VC+S4/21	100	125 - F80	1¼"	1169	1000	2000	700	1435	230	3050
EN VTS P1M 8L/6A VC+S4/32	100	125 - F80	1¼"	1169	1000	2000	700	1436	230	3050
EN VTS P1M 8C/2A LC+S4/11	100	125 - F80	1¼"	1169	1200	1600	900	1437	230	3050
EN VTS P1M 8C/3A VC+S4/16	100	125 - F80	1¼"	1169	1000	2000	700	1438	230	3050
EN VTS P1M 8C/4A VC+S4/21	100	125 - F80	1¼"	1169	1000	2000	700	1439	230	3050
EN VTS P1M 8C/5A VC+S4/32	100	125 - F80	1¼"	1199	1000	2000	700	1440	230	3050
EN VTS P1M 8C/6A VC+S4/32	100	125 - F80	1¼"	1199	1000	2300	700	1441	230	3050
EN VTS P1M 10F/1B VC+S4/11	150	200 - F125	1¼"	1434	1000	2000	700	1442	230	3050
EN VTS P1M 10F/1A VC+S4/11	150	200 - F125	1¼"	1464	1000	2000	700	1443	230	3050
EN VTS P1M 10F/2E VC+S4/11	150	200 - F125	1¼"	1464	1000	2000	700	1444	230	3050
EN VTS P1M 10F/2CD VC+S4/16	150	200 - F125	1¼"	1464	1000	2300	700	1445	230	3050
EN VTS P1M 10F/2BC VC+S4/16	150	200 - F125	1¼"	1464	1000	2300	700	1446	230	3050
EN VTS P1M 10F/3CD VC+S4/21	150	200 - F125	1¼"	1464	1000	2500	700	1447	230	3050
EN VTS P1M 10F/3B VC+S4/21	150	200 - F125	1¼"	1464	1000	2500	700	1448	230	3050
EN VTS P1M 12B/1B VC+S4/11	150	200 - F125	1¼"	1464	1000	2000	700	1449	230	3050
EN VTS P1M 12B/1A VC+S4/11	150	200 - F125	1¼"	1464	1000	2000	700	1450	230	3050
EN VTS P1M 12B/2C VC+S4/21	150	200 - F125	1¼"	1464	1000	2300	700	1451	230	3050
EN VTS P1M 12B/2B VC+S4/21	150	200 - F125	1¼"	1464	1000	2500	700	1452	230	3050
EN VTS P1M 12B/3C VC+S4/32	150	200 - F125	1¼"	1464	1000	2500	700	1453	230	3050